

NOTE:  
 DIMENSIONS ON DRAWINGS ARE THEORETICAL. FINAL DIMENSIONS ON  
 DETAIL DEPENDS ON MANUFACTURING METHOD OF WELD ASSEMBLY. FOR  
 INSTANCE MUST CONSIDERATION BE TAKEN TO SHRINKAGE WHEN WELDING

Rev.	Ver.	Position	Modified From	Date	Mod.by	Chd.by	Appd.by	CN Id
2	0	-	Holes added.	2018-01-19	IPCXSH	TMGJERI	TMGAFH	-

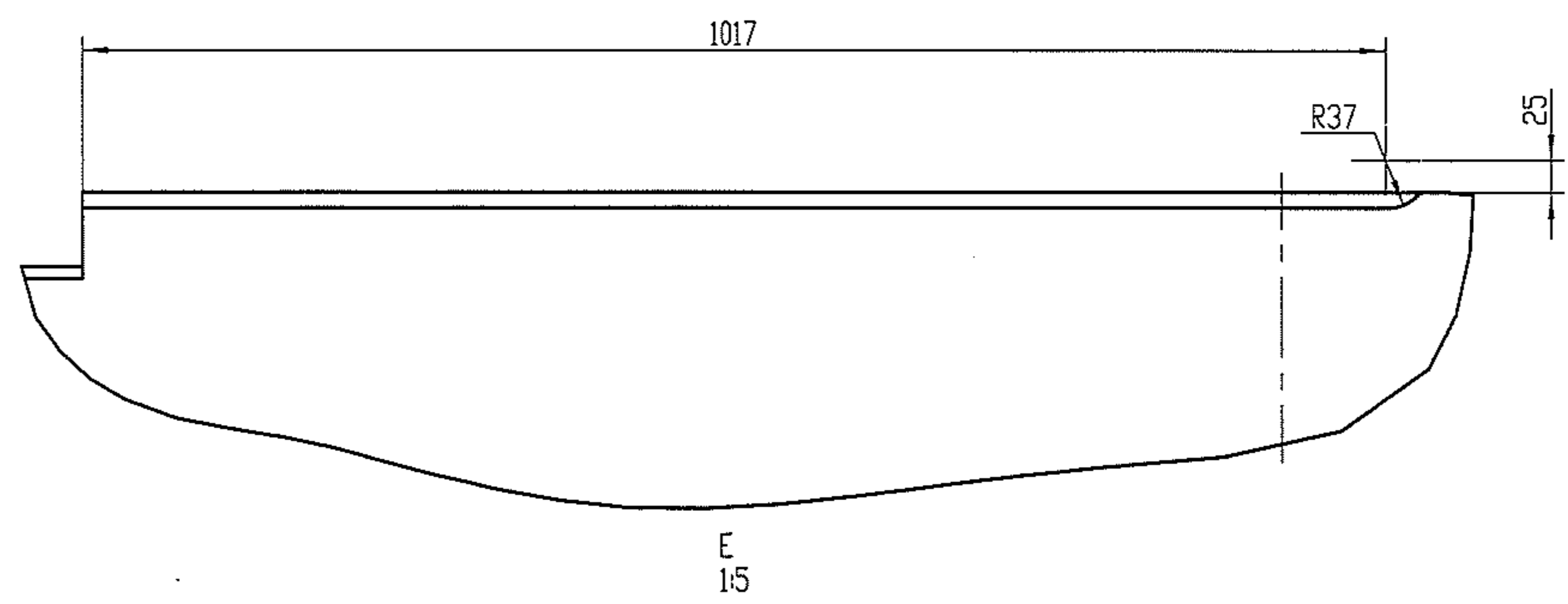
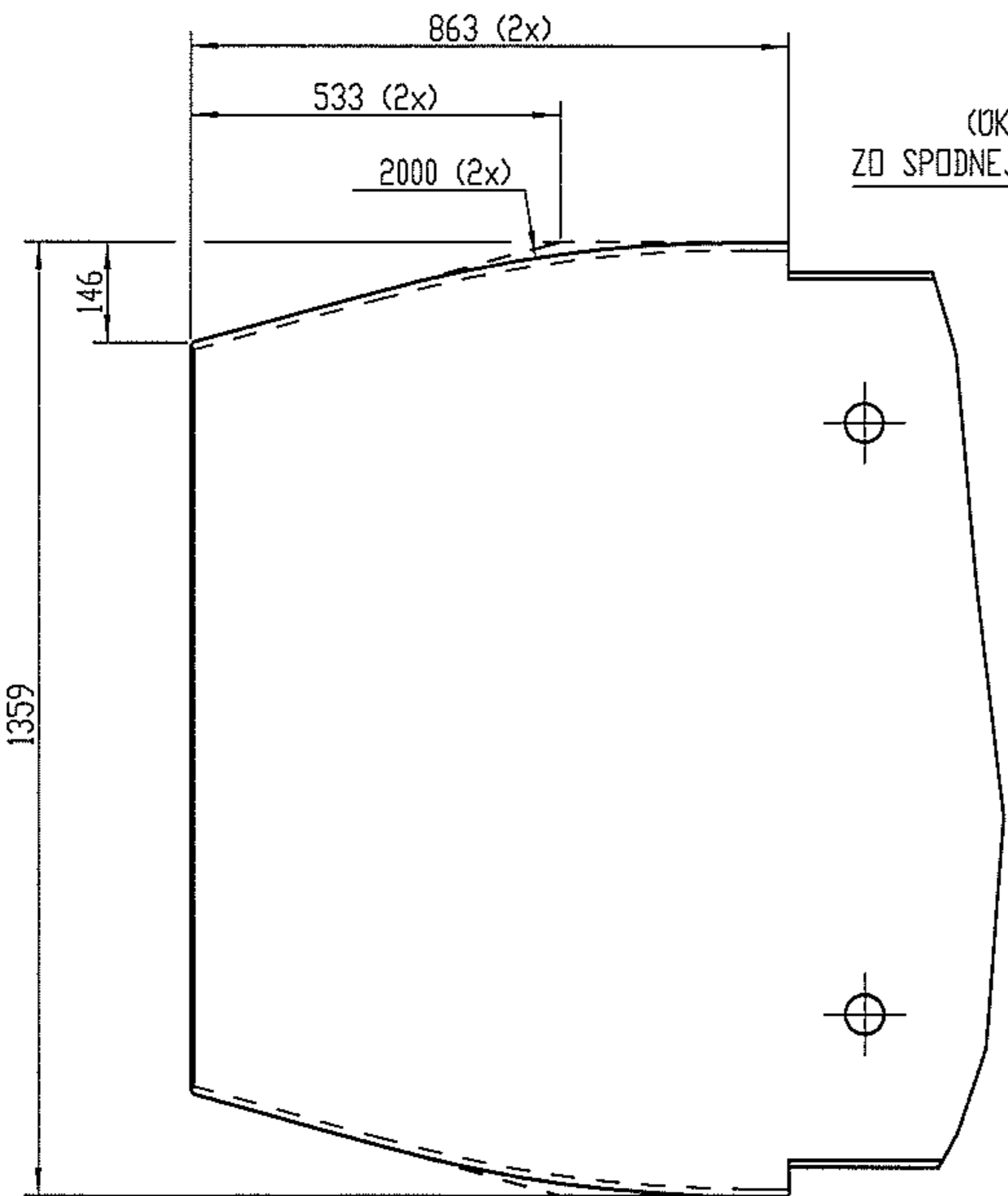
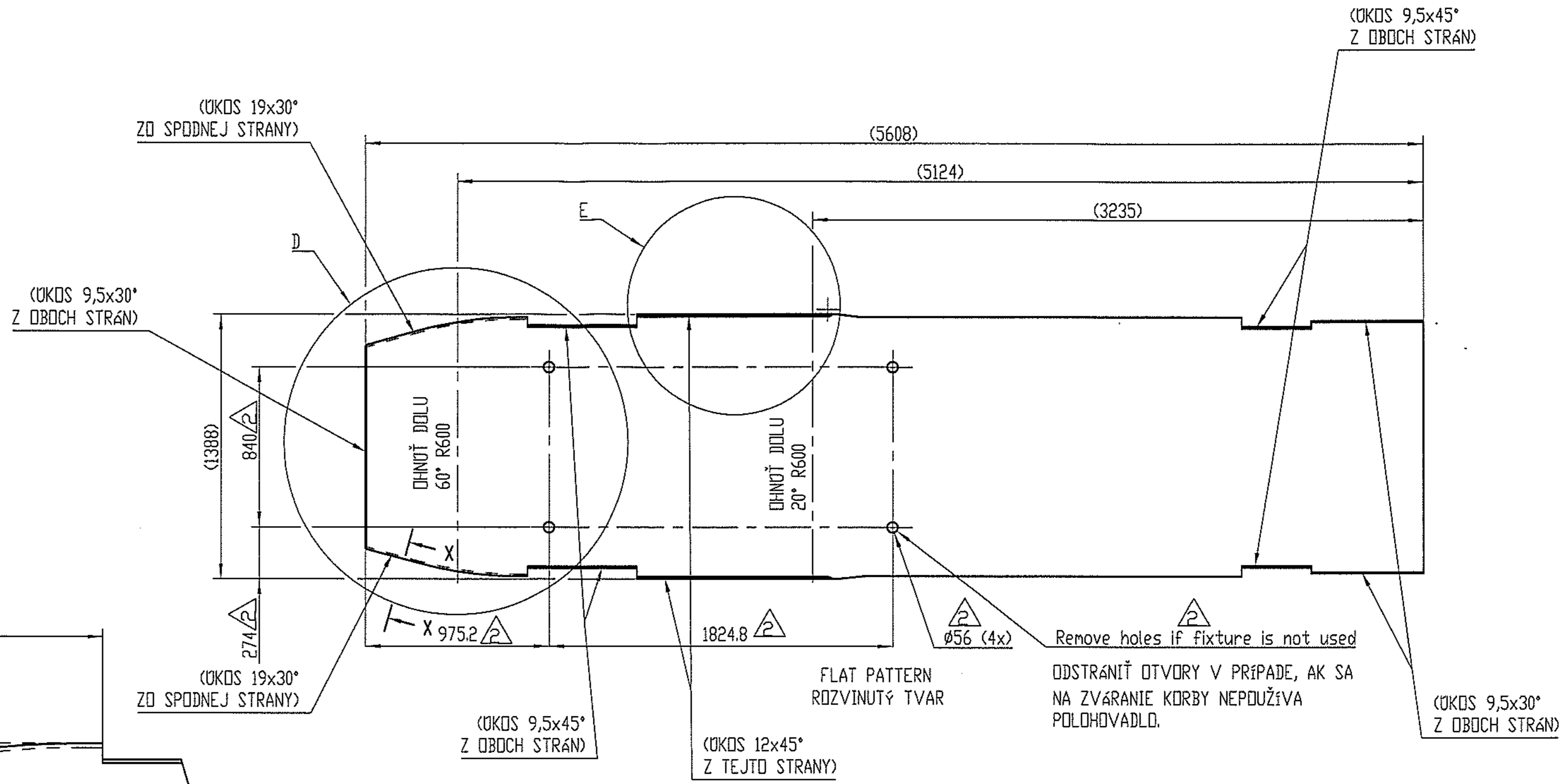
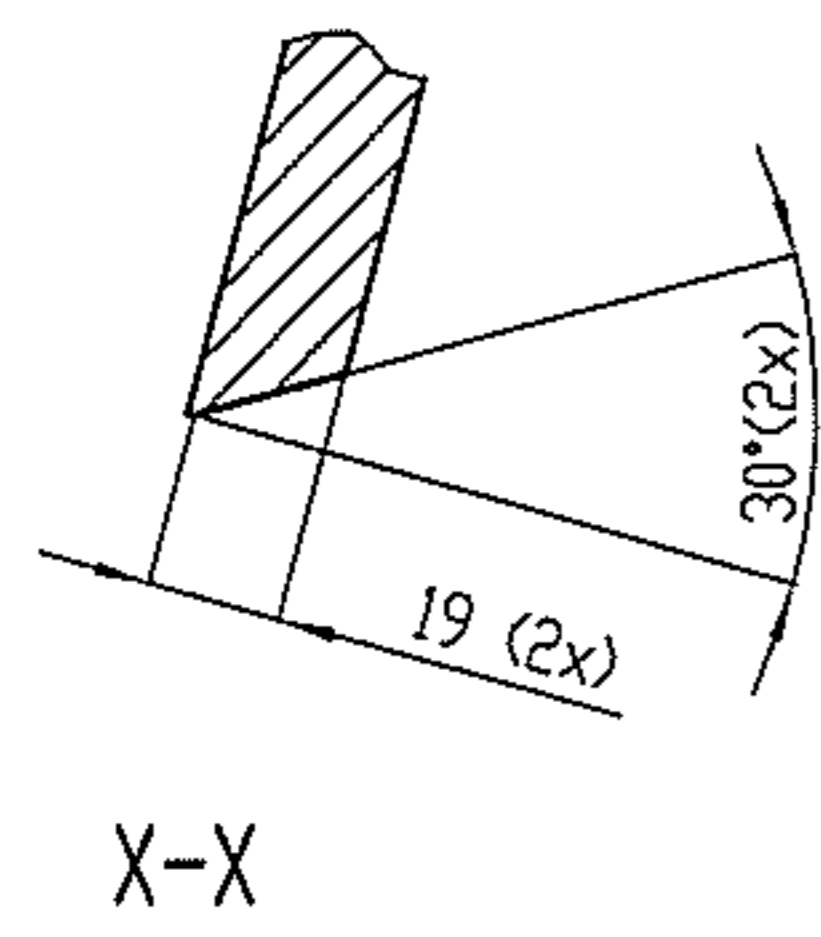

D  
1:10

2	0	-	Holes added.	2018-01-19	IPCXSH	TMGJERI	TMGAFH	-
Rev.	Ver.	Posi- tion	Modified From	Date	Mod.by	Chd.by	Appd.by	CN Id